

# World of SPC & DRYBACK

by **CHECK** ✓

VINYLFLOORING



## TABLE OF CONTENT

World of SPC / Dryback – introduction	4
<b>VILLAGE COLLECTION</b>	
Village Collection plank	7
<b>TOWN COLLECTION</b>	
Town Collection plank	9
Town Collection wide plank 229 mm	10
Town Collection wide plank 225 mm	11
Town Collection tile	12
<b>CITY COLLECTION</b>	
City Collection plank	15
City Collection wide plank 225 mm	16
City Collection wide plank 229 mm	16
<b>1x4 COLLECTION</b>	
1x4 Collection wide plank SPC / Dryback	19
1x4 Collection herringbone SPC / Dryback	20
<b>EQUIPPED</b>	
Overview accessories	22

## NEW WORLDS IN THE AREA OF HEALTHY LIVING VINYL FLOORS

Welcome to a new World of possibilities with our „World of SPC“ and „World of Dryback“ portfolio, opening up new horizons in the field of vinyl flooring. „World of SPC“ and „World of Dryback“ put the world at your feet. „With love from Germany“, the new portfolio offers a wide range of formats and designs fitted via Clicksystem and glued, all supplied with a 10-year guarantee.\* The three clearly defi-

ned collections of „Village“, „Town“ and „City“ offer a wide range of possibilities from entry level to heavy usage. Each offers something different within classic, wide and tile formats. Timeless and modern decors with 4V-groove options and the innovation of structured surfaces make the „World of SPC“ and „World of Dryback“ portfolio perfect for all your requirements.

### WORLD OF SPC

The „World of SPC“ floors, laid using the Clicksystem, have a plasticizer-free mineral base and rigid carrier board, which not only offers superb stability, but is also resistant to heat and moisture. These floors are therefore particularly suitable for residential areas subject to heavy use and can be laid up to floor-to-ceiling windows, in conservatories, bathrooms and kitchens. These SPC Vinyl floors are also ideal for renovation and refurbishment work, such as installation over existing sub-floors due to their rigid backing plate and low installation height.

#### ADVANTAGES „WORLD OF SPC“

- suitable for wet rooms, residential conservatories and floor-to-ceiling windows\*\*
- very hard-wearing
- low construction height
- plasticizer-free carrier board
- increased stability of the click connection
- suitable for underfloor heating\*
- easy to clean

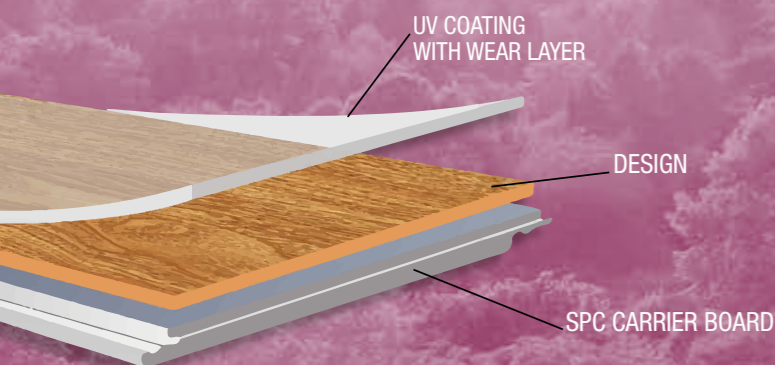

### WORLD OF DRYBACK

The „World of Dryback“ collection includes water-resistant glued floors, which combine perfectly with hot water underfloor heating systems as the heat is particularly well conducted from the subfloor to the surface thanks to the full surface-wide connection. Due to the strong bond, no additional underlay for impact noise is required to reduce walking noise. In addition, there is nothing to prevent its use up to floor-to-ceiling windows, in residential conservatories, bathrooms and kitchens. Highly resistant and warm, Dryback floors bring such advantages as their low installation height, high load-bearing capacity and long service life as well as being phthalate-free, meaning, you can be safe in the knowledge you are protecting your home and the environment.

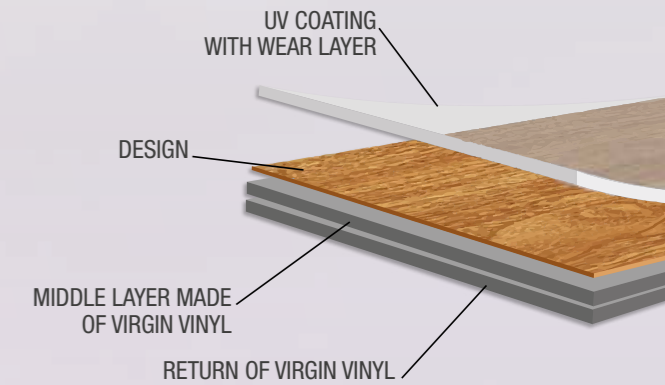

#### ADVANTAGES „WORLD OF DRYBACK“

- suitable for wet rooms, residential conservatories and floor-to-ceiling windows\*\*
- extremely hard-wearing, resilient and durable
- very low construction height
- very easy to clean
- warm to the feet
- noise-free
- phthalate-free
- suitable for underfloor heating\*

**10 YEARS**  
GUARANTEE\*

\* according to guarantee conditions  
\*\* according to manufacturer approval

# VILLAGE COLLECTION

The "Village Collection" offers a compact range in 3.5 mm thick classic format board with a 0.2 mm wear layer and utilisation class of 31. The perfect entry level range for light commercial and domestic use laid via the quick fitting Clicksystem.

## VILLAGE COLLECTION – PLANK

Dimension: 1220 x 180 x 3.5 mm

Wear Layer: 0.2 mm

Utilisation Class: 31

Panels/Box: 12

sqm/Box: 2.635

kg/Box: ca. 18.83

Box/Pallet: 48

sqm/Pallet: 126.49



**3500 CHICAGO OAK**

EAN 4250055109777

Skirting: 8058-L | Accessories Colour: Grey



**3501 HOUSTON OAK**

EAN 4250055109784

Skirting: 3501-L | Accessories Colour: Maple



**3502 PHOENIX OAK**

EAN 4250055109791

Skirting: 2411-L | Accessories Colour: Grey

Clicksystem: Loc-Click

# TOWN COLLECTION

The „Town Collection“ expands the selection and introduces both wide and tile formats in addition to the classic with quick fitting Clicksystem. These three formats in an expanded selection of decors open up a myriad of options and possibilities. Thanks to the 4 mm thickness, 0.3 mm wear layer and utilisation class 32 this comprehensive portfolio of products can be laid in areas with average residential or commercial use. To add elegance to any area all boards are also supplied with a 4-sided bevel and 4V-groove.

## TOWN COLLECTION – PLANK

Dimension: 1220 x 180 x 4 mm

Wear Layer: 0.3 mm

Utilisation Class: 32

Panels/Box: 10

sqm/Box: 2.196

kg/Box: ca. 17.77

Box/Pallet: 48

sqm/Pallet: 105.41

bevelled edge



**3503 PHILADELPHIA OAK**

EAN 4250055109807

Skirting: 3503-L | Accessories Colour: Walnut

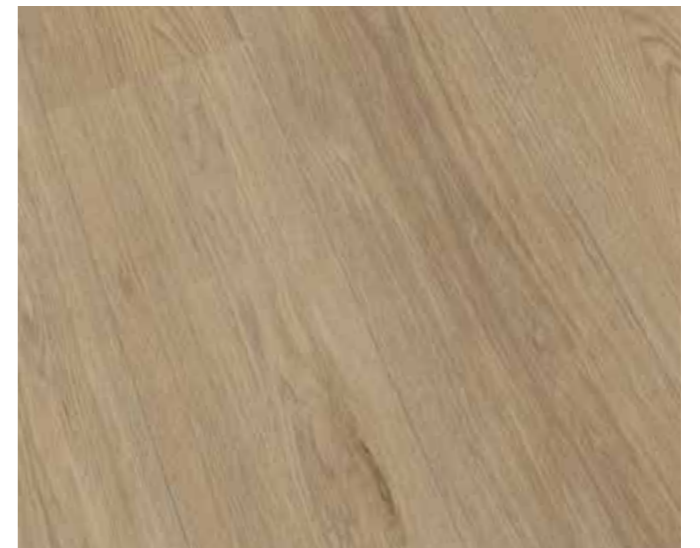

**3504 SAN ANTONIO OAK**

EAN 4250055109814

Skirting: 3504-L | Accessories Colour: Maple



**3505 SAN DIEGO OAK**

EAN 4250055109821

Skirting: 6501-L | Accessories Colour: Maple

Clicksystem: Loc-Click



**3506 DALLAS OAK**

EAN 4250055109838

Skirting: 3506-L | Accessories Colour: Grey

## TOWN COLLECTION – WIDE PLANK

Dimension: 1220 x 229 x 4 mm

Wear Layer: 0.3 mm

Utilisation Class: 32

Panels/Box: 8

sqm/Box: 2.235

kg/Box: ca. 18.09

Box/Pallet: 48

sqm/Pallet: 107.28

bevelled  
edge

Wide plank

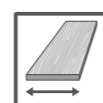
**3535 AKRON OAK**

EAN 4250055110810

Skirting: 2045-L | Accessories Colour: Maple

**3536 AMARILLO OAK**

EAN 4250055110827

Skirting: 2075-L | Accessories Colour: Maple

**3537 AURORA OAK**

EAN 4250055110834

Skirting: 3073-L | Accessories Colour: Maple

Clicksystem: Innovation-Click

**3538 BRANDON OAK**

EAN 4250055110841

Skirting: 3538-L | Accessories Colour: Maple

## TOWN COLLECTION – WIDE PLANK

Dimension: 1220 x 225 x 4 mm

Wear Layer: 0.3 mm

Utilisation Class: 32

Panels/Box: 8

sqm/Box: 2.196

kg/Box: ca. 17.77

Box/Pallet: 48

sqm/Pallet: 105.41

4V-groove Wide plank

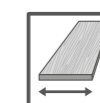
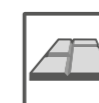
**3507 SAN JOSE OAK**

EAN 4250055109845

Skirting: 3507-L | Accessories Colour: Maple

**3508 AUSTIN OAK**

EAN 4250055109852

Skirting: 8161-L | Accessories Colour: Oak

**3509 JACKSONVILLE OAK**

EAN 4250055109869

Skirting: 2416-L | Accessories Colour: Grey

Clicksystem: Loc-Click

**3510 CHARLOTTE OAK**

EAN 4250055109876

Skirting: 2411-L | Accessories Colour: Grey

## TOWN COLLECTION – TILE

Dimension: 610 x 305 x 4 mm

Wear Layer: 0.3 mm

Utilisation Class: 32

Panels/Box: 10

sqm/Box: 1.861

kg/Box: ca. 15.06

Box/Pallet: 60

sqm/Pallet: 111.63

4V-groove Tile

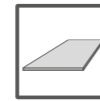
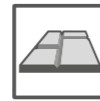

**3511 INDIANAPOLIS SLATE**

EAN 4250055109883

Skirting: 3511-L | Accessories Colour: Black



**3512 SEATTLE CONCRETE**

EAN 4250055109890

Skirting: 3512-L | Accessories Colour: Grey

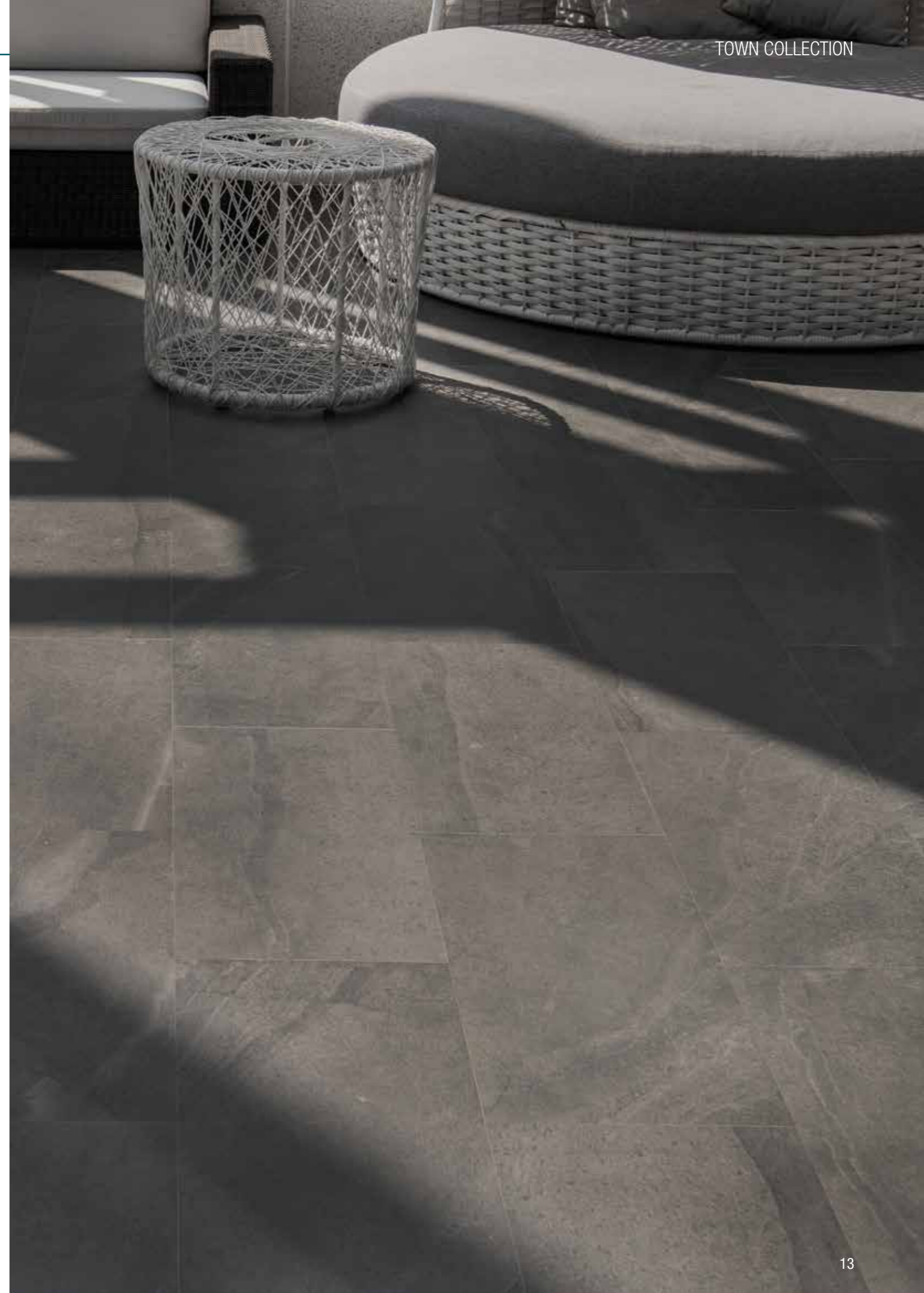

# CITY COLLECTION

The „City Collection“ also offers classic and wide board formats in upgraded specifications of 4 mm thickness, 0.5 mm wear layer and utilisation class 41. However, the real highlight in the “City Collection” is the introduction of a synchronous surface structure. The unique look and feeling of a real wood effect floor is usually only reproduced in laminate flooring. The introduction of this innovative and natural looking product portfolio heralds a new dawn in what can be possible with vinyl products.

In line with such an innovation and natural looking product comes a range of classic and modern decors all offered with 4-sided bevel with 4V-groove. The perfect way to add style, finesse and practicality to any area whether residential, commercial or trade fairs and exhibitions.

## CITY COLLECTION – PLANK

Dimension: 1220 x 180 x 4 mm

Wear Layer: 0.5 mm

Utilisation Class: 41

Panels/Box: 10

sqm/Box: 2.196

kg/Box: ca. 17.44

Box/Pallet: 48

sqm/Pallet: 105.41

bevelled  
edge

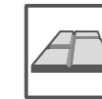

### 3513 DENVER OAK

EAN 4250055109906

Skirting: 2416-L | Accessories Colour: Grey



### 3514 WASHINGTON OAK

EAN 4250055109937

Skirting: 3514-L | Accessories Colour: Oak

Clicksystem: Loc-Click



**CITY COLLECTION – WIDE PLANK**

Dimension: 1220 x 225 x 4 mm | Wear Layer: 0.5 mm | Utilisation Class: 41 |  
 Panels/Box: 8 | sqm/Box: 2.196 | kg/Box: ca. 17.44 | Box/Pallet: 48 |  
 sqm/Pallet: 105.41

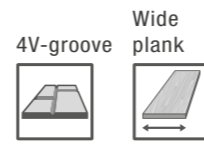

**3515 LOS ANGELES OAK**  
 EAN 4250055109944  
 Skirting: 2059-L | Accessories Colour: Silver grey



**3516 BOSTON OAK**  
 EAN 4250055109951  
 Skirting: 3516-L | Accessories Colour: Maple

Clicksystem: Loc-Click

**CITY COLLECTION – WIDE PLANK**

Dimension: 1220 x 229 x 4 mm | Wear Layer: 0.5 mm | Utilisation Class: 41 |  
 Panels/Box: 8 | sqm/Box: 2.235 | kg/Box: ca. 17.75 | Box/Pallet: 48 |  
 sqm/Pallet: 107.28

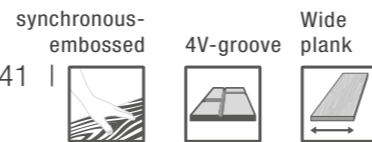

**3518 MIAMI OAK**  
 EAN 4250055110339  
 Skirting: 3518-L | Accessories Colour: Maple



**3519 CLEVELAND OAK**  
 EAN 4250055110346  
 Skirting: 2419-L | Accessories Colour: Silver grey

Clicksystem: Innovation-Click



**3520 ATLANTA OAK**  
 EAN 4250055110353  
 Skirting: 3520-L | Accessories Colour: Beech



**3521 BALTIMORE OAK**  
 EAN 4250055110360  
 Skirting: 8013-L | Accessories Colour: Grey



**3522 PITTSBURGH OAK**  
 EAN 4250055110377  
 Skirting: 3522-L | Accessories Colour: Walnut



**3523 CINCINNATI OAK**  
 EAN 4250055110384  
 Skirting: 3523-L | Accessories Colour: Oak

Clicksystem: Innovation-Click

# 1x4 COLLECTION

In the „1x4 Collection“ we present every stunning decor in 4 variations. The portfolio combines both SPC vinyl and Dryback options both in luxurious wide plank and classically appointed Herringbone formats. The SPC vinyl variations in Clicksystem installation style are available in 4 mm thickness with a 0.5 mm wear layer and utilisation class 41. The Dryback options offer 2.5 mm thickness with 0.5 mm wear layer and utilisation class 41. The finishing touch is a 4V-groove, which is located both lengthwise and widthwise around each board providing a striking but elegant appearance.

## 1x4 COLLECTION – WIDE PLANK SPC

Dimension: 1220 x 228 x 4 mm | Wear Layer: 0.5 mm | Utilisation Class: 41 | Panels/Box: 8 | sqm/Box: 2.225 | kg/Box: ca. 17.80 | Box/Pallet: 48 | sqm/Pallet: 106.81

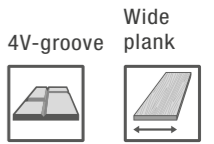

## 1x4 COLLECTION – WIDE PLANK DRYBACK

Dimension: 1219 x 229 x 2.5 mm | Wear Layer: 0.5 mm | Utilisation Class: 41 | Panels/Box: 16 | sqm/Box: 4.466 | kg/Box: ca. 20.10 | Box/Pallet: 45 | sqm/Pallet: 200.99

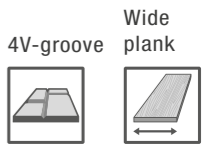

### SAN FRANCISCO OAK

**3524** EAN 4250055110582 (CLICK)  
**3524E** EAN 4250055110629 (BONDING)  
 Skirting: 2987-L | Accessories Colour: Maple



### NEW ORLEANS OAK

**3525** EAN 4250055110599 (CLICK)  
**3525E** EAN 4250055110636 (BONDING)  
 Skirting: 3525-L | Accessories Colour: Maple



### ST. LOUIS OAK

**3526** EAN 4250055110605 (CLICK)  
**3526E** EAN 4250055110643 (BONDING)  
 Skirting: 2002-L | Accessories Colour: Silver grey



### SALT LAKE CITY OAK

**3527** EAN 4250055110612 (CLICK)  
**3527E** EAN 4250055110650 (BONDING)  
 Skirting: 3527-L | Accessories Colour: Oak

Clicksystem: Loc-Click (SPC), Bonding (Dryback)

**1x4 COLLECTION – HERRINGBONE SPC**

Dimension: 550 x 110 x 4 mm | Wear Layer: 0.5 mm | Utilisation Class: 41 |  
 Panels/Box: 26 | sqm/Box: 1.573 | kg/Box: ca. 12.58 | Box/Pallet: 72 |  
 sqm/Pallet: 113.26

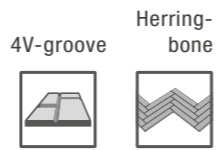

**1x4 COLLECTION – HERRINGBONE DRYBACK**

Dimension: 600 x 120 x 2.5 mm | Wear Layer: 0.5 mm | Utilisation Class: 41 |  
 Panels/Box: 48 | sqm/Box: 3.456 | kg/Box: ca. 15.55 | Box/Pallet: 60 |  
 sqm/Pallet: 207.36

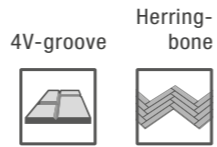

**SAN FRANCISCO OAK**

**3524H** EAN 4250055110667 (CLICK)  
**3524HE** EAN 4250055110704 (BONDING)  
 Skirting: 2987-L | Accessories Colour: Maple

**NEW ORLEANS OAK**

**3525H** EAN 4250055110674 (CLICK)  
**3525HE** EAN 4250055110711 (BONDING)  
 Skirting: 3525-L | Accessories Colour: Maple



**ST. LOUIS OAK**

**3526H** EAN 4250055110681 (CLICK)  
**3526HE** EAN 4250055110728 (BONDING)  
 Skirting: 2002-L | Accessories Colour: Silver grey

**SALT LAKE CITY OAK**

**3527H** EAN 4250055110698 (CLICK)  
**3527HE** EAN 4250055110735 (BONDING)  
 Skirting: 3527-L | Accessories Colour: Oak

Clicksystem: Push-Click (SPC), Bonding (Dryback)



# »EQUIPPED«

**EQUIPPED** is the accessory brand we recommend for our products. You get a trim-coordinated strip for each vinyl floor, which allows you to hide a cable behind it with the option of attaching it to the wall via a clip system.

In addition, unsightly bumps, where two bars mounted side by side meet, can be avoided by using connectors. It is also recommended to install **EQUIPPED** accessories in interior or exterior corners. You save yourself the miter sawing. Rounded off by end caps on protrusions or door frames, the range offers everything needed to complete the installation.

Our Equipped underlay or impact sound insulation also offers a comprehensive and quality range.

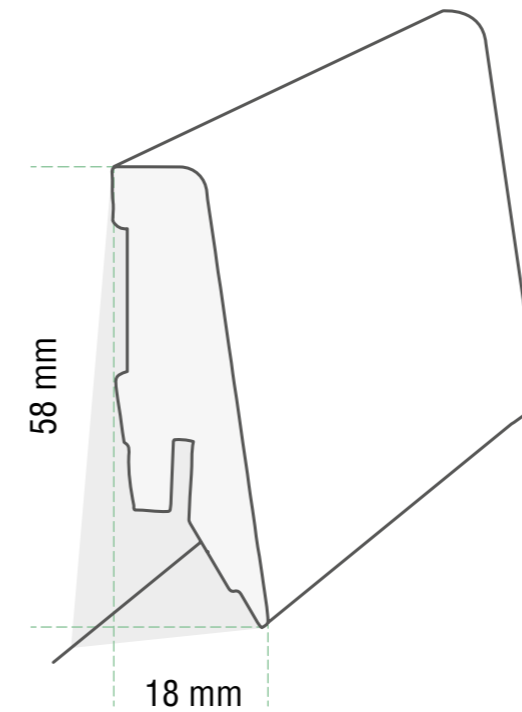

The matching Equipped skirting, with a height of 58 mm in a modern profile, are assigned to the respective decors on the previous pages.

You can also find our edge strips at [check-floors.com](http://check-floors.com).

**White skirting boards** are also available in other designs and sizes.

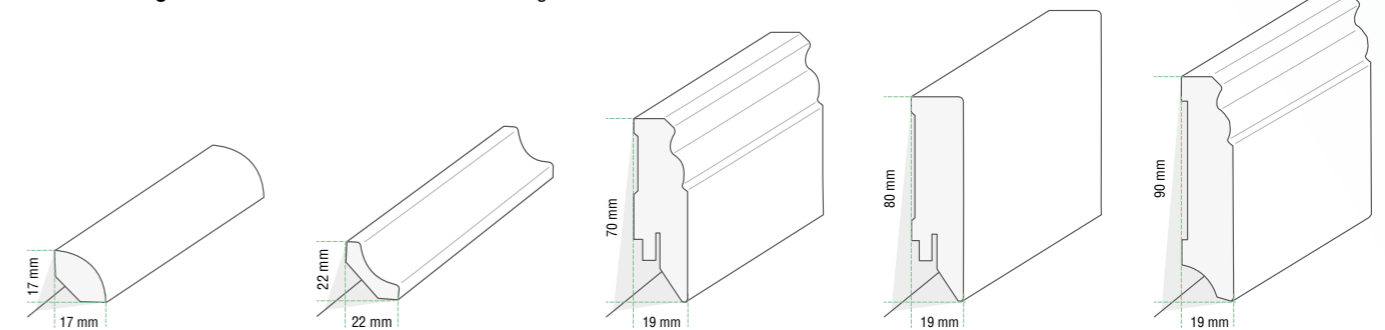

All corners, connectors and end caps are available in the following colours:



# World of SPC    World of DRYBACK

by **CHECK** ✓

**Our team is here for you.**  
Send us your requirements and we will solve them.  
Our logistics and sales network can handle almost any task.

© Image sources i.a. Koczwarra, Adobe Stock

**CHECK is a brand of:**  
Koczwarra Vertriebs-GmbH  
Scheuten-Solar-Straße 2  
45881 Gelsenkirchen  
GERMANY  
[check-floors.com](http://check-floors.com)